

MATERIAL

Fine ground, hardened and black-oxide steel (tensile strength 1220±1400 N/mm²).

FEATURES AND APPLICATIONS

GN 6339 washers have been studied for heavy applications allowing to reach and keep a high closing force.

For a specified preload closing force, it is often possible to use small sized screws, thanks to a better ratio between the closing distance and the screw diameter, thus minimising the danger of breakage.

The smooth and hardened surface minimises friction, also when continuous tightening and releasing operations are required.

GN 6339 washers are designed for class 8.8/10.9/12.9 steel screws.

OUTSIDE DIAMETER D2

Normal thickness washers, d2 is compliant with DIN 125 / ISO 7089 standards (see table). High thickness washers, d2 is compliant with DIN 7349 standards (see table).

DIAMETER D3

Along with chamfer 70° and inside diameter d1, diameter d3 is the most important dimension in these types of washers. It is always greater than the maximum diameter of the screw underhead, even in the minimum tolerance condition. In this way, the chamfer of diameter d3 of the washer will not be pressed by the underhead radius, thus causing a cut into the screw which could damage it.

INSIDE DIAMETER D1

The inside diameter d1 is kept as small as possible to ensure the best centring in inserting the screw. The screw and washer centring with the least radial clearance is important to prevent faulty assembly between diameter d3 and the maximum contact area of the screw head diameter.

ANGLE CHAMFER = 70° ± 2°

This relatively wide angle allows better assembly of the washer with hexagonal head screws which usually have a cone-shaped head base.

CHAMFERED SURFACE F

The chamfered surface F, with dimension d3 and d1, ensures minimal clearance so as to allow better assembly of the washer with the screws that have a cone-shaped head base. Even in the worst condition of smaller angle (68°) and smaller dimensions of diameters d3 and d1, the radial clearance for all the screws according to the DIN EN standards is still sufficient.

**DIMENSION H**

Dimension h is the height of the cylindrical part of the inside diameter d1 and should be the largest possible in relation to the screw thread pitch.

WASHER THICKNESS S

The thickness of GN 6339 washers is larger than DIN washers. A larger thickness means greater washer solidity.

SPECIAL EXECUTIONS ON REQUEST

Fine ground and hardened steel washers, with GEOMET 500 treatment (GO).

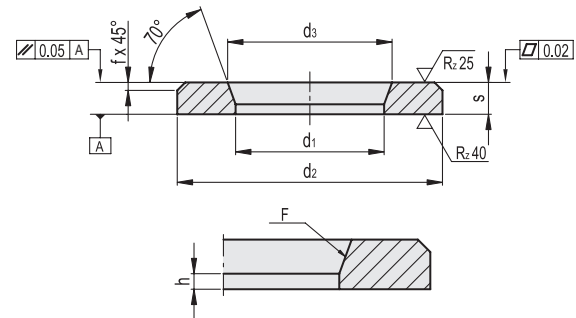

METRIC

Code	Description	d1 H13	d2 H13	d3 H13	f	s	For threaded pin	DIN 125	DIN 7349	⚖️
GN.10641	GN 6339-6.3-12-2.5-BT	6.3	12	7	0.6	2.5	M6	•	-	2
GN.10642	GN 6339-6.3-17-3-BT	6.3	17	7	1	3	M6	-	•	2
GN.10646	GN 6339-8.4-16-2.5-BT	8.4	16	9.5	0.75	2.5	M8	•	-	3
GN.10647	GN 6339-8.4-21-4-BT	8.4	21	9.5	1.5	4	M8	-	•	8
GN.10651	GN 6339-10.4-20-3-BT	10.4	20	11.5	0.75	3	M10	•	-	5
GN.10652	GN 6339-10.4-25-4-BT	10.4	25	11.5	1.5	4	M10	-	•	12
GN.10656	GN 6339-12.5-24-3.5-BT	12.5	24	14	1	3.5	M12	•	-	8
GN.10657	GN 6339-12.5-30-6-BT	12.5	30	14	2	6	M12	-	•	24
GN.10661	GN 6339-14.5-28-3.5-BT	14.5	28	16	1	3.5	M14	•	-	12
GN.10662	GN 6339-14.5-36-6-BT	14.5	36	16	2	6	M14	-	•	38
GN.10666	GN 6339-16.5-30-4-BT	16.5	30	18	1	4	M16	•	-	10
GN.10667	GN 6339-16.5-40-6-BT	16.5	40	18	2	6	M16	-	•	47
GN.10671	GN 6339-18.5-34-5-BT	18.5	34	21	1.5	5	M18	•	-	23
GN.10672	GN 6339-18.5-44-8-BT	18.5	44	21	2.5	8	M18	-	•	73
GN.10676	GN 6339-20.5-37-5-BT	20.5	37	23	1.5	5	M20	•	-	27
GN.10677	GN 6339-20.5-44-8-BT	20.5	44	23	2.5	8	M20	-	•	71
GN.10681	GN 6339-22.5-40-5-BT	22.5	40	25	1.5	5	M22	•	-	30
GN.10682	GN 6339-22.5-50-8-BT	22.5	50	25	2.5	8	M22	-	•	93
GN.10686	GN 6339-24.5-44-5-BT	24.5	44	27	1.5	5	M24	•	-	38
GN.10687	GN 6339-24.5-50-10-BT	24.5	50	27	3.5	10	M24	-	•	38
GN.10691	GN 6339-28-50-6-BT	28	50	31	1.5	6	M27	•	-	59
GN.10692	GN 6339-28-60-10-BT	28	60	31	3.5	10	M27	-	•	161
GN.10696	GN 6339-31-56-6-BT	31	56	34	1.5	6	M30	•	-	77
GN.10697	GN 6339-31-68-10-BT	31	68	34	3.5	10	M30	-	•	212
GN.10699	GN 6339-37-66-7-BT	37	66	40	2	7	M36	•	-	121

